

STI FIRE EXTINGUISHER THEFT STOPPER®

**Wireless
Available**



STI-6200

PRODUCT OVERVIEW

If you are fed up with replacing your fire extinguishers, this sturdy, tamperproof, self-contained alarm is the answer. It has proven highly effective in helping prevent theft, misuse or vandalism of fire extinguishers. Yet, it leaves the extinguisher accessible for emergencies and does not interfere with fire fighting in any way.

HOW IT WORKS

If the protected fire extinguisher is moved from its normal position, the device emits a piercing alarm. Also, the highly visible stop sign design and the words "STOP, ALARM WILL SOUND" discourages wrongful use. The device is easy to install and a deactivation cable is supplied for ease in servicing the extinguisher. A 9 VDC alkaline battery is included.

KEY FEATURES

General Information

- Highly visible "stop" sign design discourages wrongful use of extinguisher.
- Deactivation cable provided for service by authorized personnel.
- Three year guarantee against breakage of polycarbonate in normal use (one year on electro mechanical and electronic components).

Design

- Compact design 5.375 in. (137mm) in diameter and 2 in. (51mm deep). Mounts easily next to extinguisher.
- Add warning in second language with provided labels (20 languages).

Construction

- Virtually indestructible polycarbonate housing.

Installation

- For fire extinguishers housed in cabinets, refer to STI-6255 Mini Theft Stopper®.

Electronics

- Sounds a powerful warning horn when activated, drawing attention in a hurry.
- 9 VDC alkaline battery is provided.
- Volume:
HI 112dB @ 1 ft., 103dB @ 3 ft.
LOW 109dB @ 1 ft., 98dB @ 3 ft.

Options

- STI-6200WIR supervised wireless 433 MHz (4 or 8-Channel Receiver required). Operates up to 1000' (line of sight).
- 12 VDC powered model available for special applications (STI-6200R).



STI Fire Extinguisher Theft Stopper®

Dimensions and Technical Information

MODELS AVAILABLE

STI-6200	Fire Extinguisher Theft Stopper
STI-6200R	Fire Extinguisher Theft Stopper with 12 volt powered horn (power supply sold separately)
STI-6200WIR	Wireless Fire Extinguisher Theft Stopper
STI-6200WIR8	Wireless Fire Extinguisher Theft Stopper with 8-Channel Receiver
STI-6200WIR9	Wireless Fire Extinguisher Theft Stopper with Single Channel Slave Receiver
STI-V6200WIR4	Wireless Fire Extinguisher Theft Stopper with 4-Channel Voice Receiver
STI-34098	Single Channel Slave Receiver
STI-34108	8-Channel Receiver
STI-V34104	4-Channel Voice Receiver
KIT-18015-9	6 in. deactivation cable used during service times
KIT-18015-RC	Replacement cable and crimp 16-18 in. long
KIT-6702	Tamper proof screw and wrench
KIT-H19016	Tamper wrench, set of 2

APPROVALS & WARRANTY

STI-6200, STI-6200WIR & STI-6200WIR4
It has been tested and approved or listed by:

- FCC & IC Compliant
- CE Approved

WARRANTY

Three year guarantee against breakage of polycarbonate in normal use (one year on electro mechanical and electronic components).

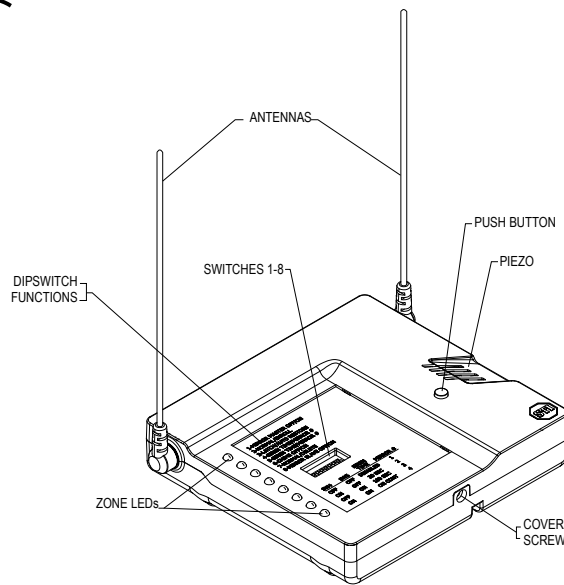
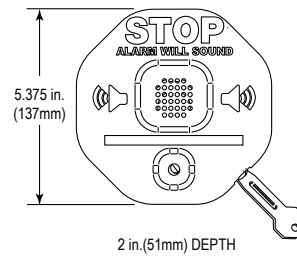
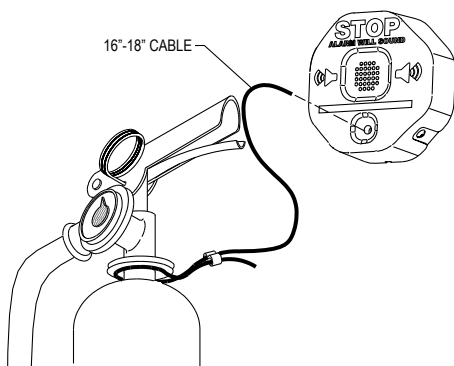

STI-34108



Safety Technology International

Waterford, M
48327, USA 48327,

Taylor House
34 Sherwood Rd., B
Worcs., B60 3DR, England

Unit 7A Lockheed Avenue
Airport Business Park
Waterford X91 HWF2 Ireland